

INSTRUCTIONS

NR-210 Day Trip

Please read instructions carefully before installation. We recommend this product be installed by a qualified and experienced motorcycle technician. If you are unsure of any of the below directions and/or your ability to correctly and securely install this product, please contact us or your local dealer for help. Below diagrams show typical installation, your motorcycle may be different so please use diagrams as a guide. Make sure your motorcycle is clean and free from dirt, road grime, etc. where the Nelson-Rigg luggage mounts.

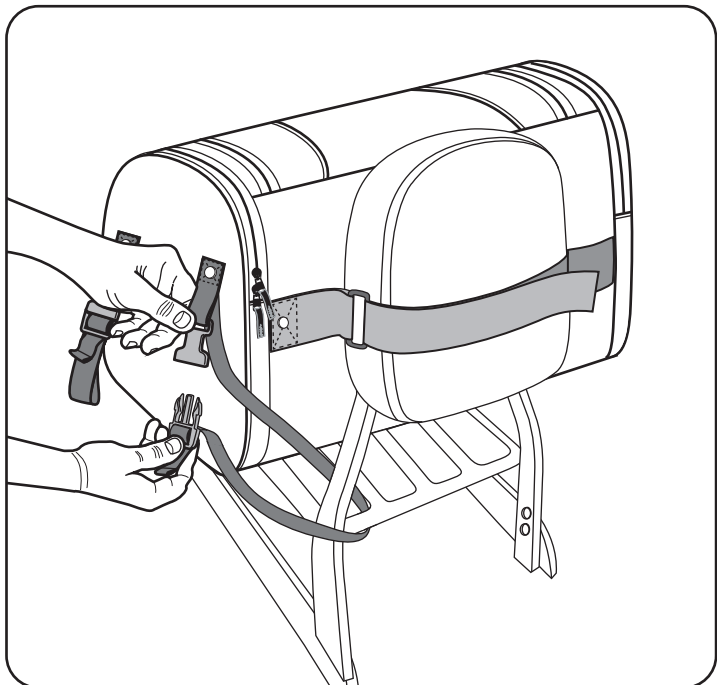

With bag sitting on a luggage rack or passenger seat, loosen self fastening straps. With straps passing through "D" ring, slide over your backrest. Pull to tighten and lay the strap back onto itself, connecting the self fastening straps. For the side attachments pass the strap with the male buckle around the luggage rack or frame and reconnect with the female buckle attached to the bag. Make sure the male buckle clicks into place. Repeat this on all 4 straps on the bag. Make sure the bag has little if any movement up, down or left and right before riding. Always recheck mounting before every ride.

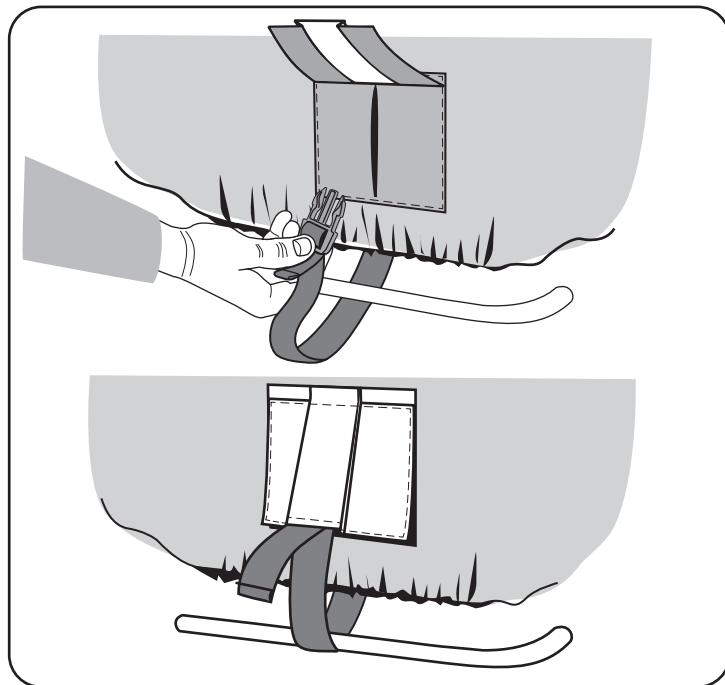

In case of inclement weather or even to keep your bag cleaner, use the included waterproof rain cover to protect your bag. After the bag is completely covered and the bottom bungee wraps around under the bag, secure the rain cover using the side attachment straps. Pass the strap with the male buckle around the luggage rack or frame, lift the rain cover flap and insert the buckle through the slot and reconnect into female buckle under the cover. Fasten the cover flap closed. Repeat on all 4 straps on the bag.



NR-210 Day Trip can also be used as a top mount for NR-200 Highway Roller bag. See next picture for mounting instructions.

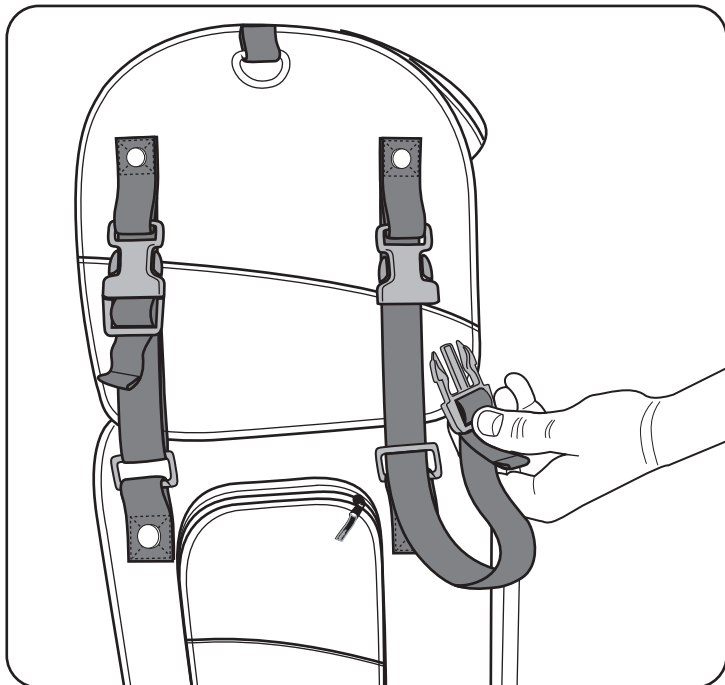

Place the NR-210 Day trip bag on top of the Highway roller making sure the bag is centered and laying flat. Use mounting straps on both sides of Day Trip bag and the square rings on Highway Roller to connect the two bags. Pass the strap with the male buckle through the square ring and reconnect with the female buckle attached to the NR-210 Day Trip. Make sure the male buckle clicks when inserted. Repeat on all 4 straps on the bag.

Warning

Read the installation instructions and make yourself familiar with the process of installing the Nelson-Rigg® product(s) on your bike. It is your responsibility to mount the product correctly as outlined in these instructions. Nelson-Rigg® products are intended for use at USA street legal speeds as posted by the individual States. Nelson-Rigg® luggage must not be overloaded. Max carrying capacity is 10 lbs per bag or the maximum load suggested by the manufacturer of the vehicle, whichever is less. Failure to adhere to these warnings may result, but not limited to: the luggage becoming detached, the product becoming tangled in moving parts of the vehicle, unstable vehicle dynamics, reduction in the ability to control the vehicle. The result(s) of could lead to serious injury. **Always ride safely, adhering to the local highway regulations. Always wear a helmet and protective apparel.**

3518-A Lake Center Dr. Santa Ana, CA 92704
Tel (714)850-1811 Fax (714)850-1848
E-mail: info@nelsonrigg.com www.nelsonrigg.com

